

DZOFILM
MAKE YOUR MOVIE

GNOSIS MACRO PRIME LENS USER'S MANUAL

观系列微距定焦镜头使用说明书

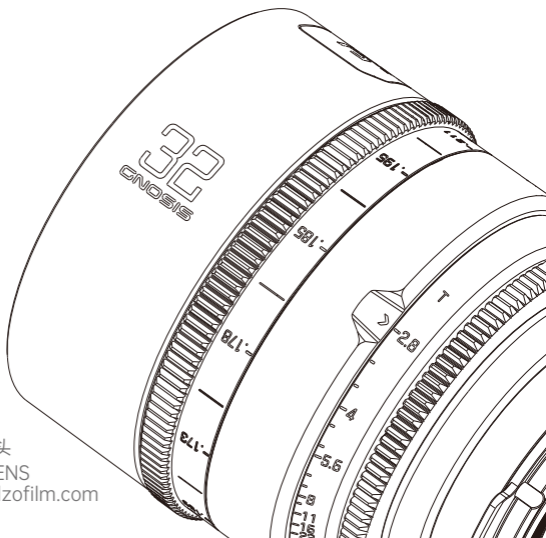

电影镜头
CINE LENS
www.dzofilm.com

Contents

Introduction	1
Safety Notes.....	1
Lens Parts	2
Lens Control.....	3
Flange Back Adjustment.....	5
1. Preparation.....	5
2. Flange Back Adjustment	6
Specification.....	8
After-sales Service	9
The Name and Content of Hazardous Substances.....	11

Note

 Click to go

Users can read the table of content(TOC) to have an overview of the Gnosis Product Manual. Please click on the title or link to jump to the TOC

 Search keyword

The Search-keyword Function is available in PDF Document. For example, In WPS Office, Windows users can search keywords with the keyboard shortcut <Ctrl+F> and Mac users can execute the same function with shortcut <Command+F>

Introduction

Thank you for purchasing this product!

Gnosis is DZOFILM's high-performance full frame cinema prime macro lens. It allows you to reproduce the details and color in filming. Clear images, natural transition from in-focus to defocus and minimal breathing in focusing...all these can be found in Gnosis. They are suitable for different macro creation and can adapt to a wider range of subjects such as flowers and insects, bringing audience with pure and vivid image texture and natural transition of focus shifting. Precisely control and shift the focus with a 300 degree rotation to get a stable and comfortable performance.

The industry standard front diameter of 114mm is compatible with matte boxes and other accessories, eliminating the need for repeated adjustments when changing lenses and greatly enhancing shooting efficiency.

Safety Notes

- Please do not watch the sun or bright light source through the lens, otherwise it will cause visually disabled;
- Never use organic solvents such as paint thinner or benzene to clean the lens;
- Attach the front and rear caps when the lens is not in use;
- Store the lens and filter in cool, dry locations to prevent mold and rust. Do not store in direct sunlight or with naphtha or camphor moth balls;
- Please keep the lens dry and wipe the water droplets off if there are water droplets on the glass surface;
- Leaving the lens near heater or in other extremely hot locations could cause damage or warping;
- Use a blower to remove dust and lint from the glass surfaces of the lens or filter. To remove smudges and fingerprints, apply a small amount of lens cleaner to a soft, clean cotton cloth or lens-cleaning tissue and clean from the center outwards using a circular motion. Do not leave smears or touch the glass with your finger.

Lens Parts

- ① Front Cap
- ② Lens Mark
- ③ Focusing Ring
- ④ Holes for Supporting Base*1
(M3/8-16 thread, 9mm deep)
Mounting holes *2
(M3,3mm deep)
- ⑤ Aperture Ring
- ⑥ Rear Cap
- ⑦ Magnification Ratio, Exposure Compensation Identification

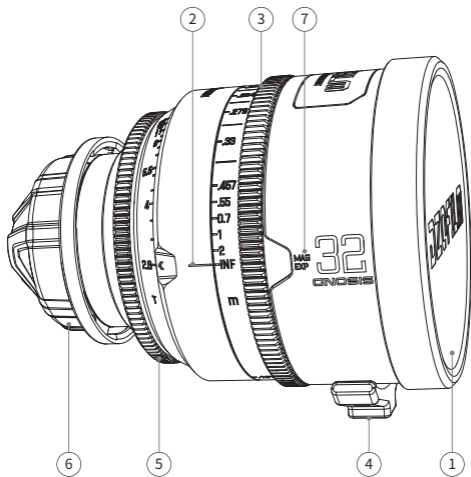

Lens Control

Focus Control

Rotate the focus ring to increase or decrease the focus distance.

Focusing Ring

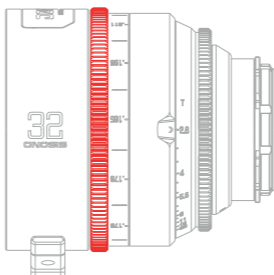

Aperture Control

Rotate the aperture ring to stop aperture down, raising the T-stop and narrowing the aperture, or lower the T-stop to widen the aperture.

Aperture Ring

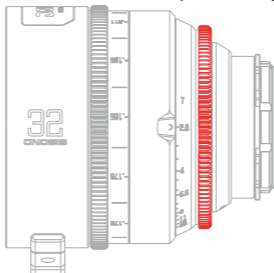

Magnification Ratio、 Exposure Compensation Identification

Magnification Ratio: the magnification ratio under ongoing focusing distance.

Exposure Compensation: the difference between actual T value and the directing T value on aperture ring. When the Exposure compensation identification is **4.18**, Actual T Value=T Value showing on the aperture ring+**4.18**.

Magnification Ratio、 Exposure Compensation Identification

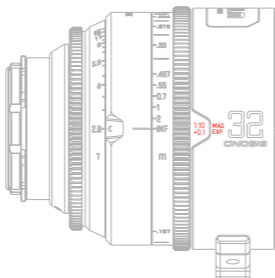

Every Gnosis lens will process flange back adjustment on standard. But due to the tolerance of different cameras, to achieve the best performance of this product and to match the cameras, please adjust flange back of the product.

1.Preparation

Take **Gnosis 32mm** as an example:

Step One: Ready your subject and calibration tool. You can use a "Star Chart", or other high-resolution black-and-white objects;download the "Back focus Calibration Tool for Prime Lens"[\(short for "Calibration Tool"\)](#) on the official website.

Note: You can download and print the chart on DZOFILM website-Download-Star Chart for Adjusting Back Flange [\(Click to jump to the website\)](#)

Step Two: Attach the lens to the camera and adjust the aperture to **T4**;

Step Three: Make the pointer align with the **0.33m** scale on focusing ring, paste calibration tool on the ring with middle line of the tool aligning the **0.33m** scale and the scale pointer (or choose **1'1** focusing scale).

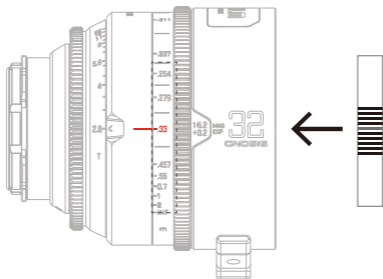

Step Four: Set the object **0.33m** away from the camera sensor plane, and adjust it to the center of the whole image.

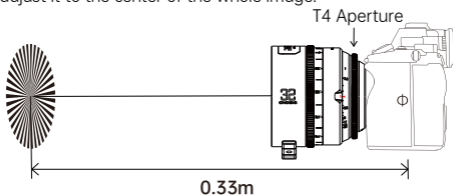

Set the object **0.33m** away from the camera sensor plane, and adjust it to the center of the whole image.

2.Flange Back Adjustment

Please adjust as the following steps:

Step One: Rotate the focus ring until the image to its clearest. Take the horizontal line in the middle of the calibration tool as the reference and observe the position of the deviating scale pointer to get the number of horizontal lines.

Note: The direction of infinity indicates positive deviation value.

The direction of the closest focusing distance indicates negative deviation value.

If there are more than **three** horizontal lines, add or subtract the corresponding value.

Example: If the scale pointer points to **3** spaces in the direction of the closest focusing distance, the deviation value is **-3**.

If the scale pointer points to **4** spaces in the direction of infinity, the deviation value is **+4**. At this situation, the shim value of "**+3**" needs to be added to the shim value of "**+1**".

Step Two: According to the deviation value and the reference below, add or subtract the corresponding shim to complete the flange back adjustment.

Gnosis Adjustment Reference									
direction			direction of the closest focusing distance				direction of infinity		
focal length	mark value	deviation value	-3	-2	-1	0	+1	+2	+3
32mm	0.33m/1'1	shim adjustment reference (mm)	-0.68	-0.52	-0.25	0	+0.22	+0.41	+0.65
65mm	0.32m/12.6"		-1.7	-1.16	-0.55	0	+0.56	+1.1	+1.7
90mm	0.291m/1'		-2.14	-1.4	-0.88	0	+0.72	+1.48	+2.32

Note: Shim adjustment: "+" means adding shims, and "-" decreasing shims.

Specification

Specification			
Name	Gnosis		
Colour	Black		
Focal Length	32mm	65mm	90mm
Mount	LPL/PL/EF		
Aperture	T2.8-T22		
Image Circle	ƒ 46.5mm(VV/FF)		
Construction of Optics	11 Elements in 9 Groups	11 Elements in 8 Groups	11 Elements in 9 Groups
Flange Distance	44mm(LPL)/52mm(PL)/44mm(EF)		
Close Focus (from sensor plane) (metric/imperial)	0.167m/6.6in	0.237m/9.36in	0.258m/10.2in
Max.Mag. Ratio	1.0X	1.33X	1.5X
Iris Control	Manual (max 55°)	Manual (max 67°)	Manual (Manual, max 68°)
Focus Control	Manual (max 300°)		
Front Dia. (metric/imperial)	ƒ 114mm		
Length (metric/imperial)	112mm		
Iris Blade	16		
Filter Size	M105		
Gear Pitch	0.8M		
Material	Aluminium alloy		
Weight	1460g	1447.5g	1280.5g

After-sales Service

How to Obtain After-Sales Service

If a product does not function as warranted during the warranty period, you may obtain after-sales service by contacting DZOFILM support team or DZOFILM's authorized dealers. Charges may apply for services not covered by this After-Sales Policy.

The After-Sales Policy varies with the country or region of purchase. Please contact DZOFILM for information specific to your location.

Warranty Service

DZOFILM grants a minimum warranty period of one year from the date of purchase for lenses purchased through DZOFILM's official dealers. DZOFILM warrants that each DZOFILM product that you purchase will be free from material and workmanship defects under normal use in accordance with DZOFILM's user manual and accompanying documentation during the warranty period. You may claim warranty service by returning it to the point of purchase. The owner is responsible for all shipping costs. The warranty period varies with the country or region of purchase. Stored dated receipts or other proof of purchase in a safe place, as you will need to provide a valid proof-of-purchase or receipt for the warranty service. Parts replaced during the warranty service become DZOFILM's property.

Service Outside the Warranty Period

Request for after-sales service will normally be accepted within a period of roughly 5 years following the end of production, during which time spares will be kept on hand, although owners may be offered an equivalent product during this period in the event that spares are not available. The specific cost standard is subject to DZOFILM's quotation. Compatibility with consumables and accessories for the original product is not guaranteed. To prevent waste, DZOFILM may collect returned parts or products.

Service Turn Around Time

After we receive the product, the after-sales service will generally be completed within two weeks. This turn around time does not include the time of return shipping. If there are special circumstances, we will notify you in advance.

What This After-Sales Policy Does NOT Cover

This after-sales policy does not cover the following and charges may apply:

- × No valid proof-of-purchase or receipt of the product;
- × Damage caused by unauthorized modification, disassembly, or repair not in accordance with official instructions or manuals.
- × Damage caused by improper installation and operation not in accordance with official instructions or manuals.
- × Damage caused by the storage environment not in accordance with official instructions or manuals.
- × Damage caused by operation in bad weather or environment (i.e. rain, sand/dust storms, humid environment, etc.).
- × Damage caused by, any third party products, including those that DZOFILM may provide or integrate into the DZOFILM product at your request.
- × Damage caused by any third-party product.
- × Damage caused by force majeure;
- × Consumable accessories and optional parts that come with this product.

Privacy

DZOFILM obeys all applicable laws and regulations concerning the handling of names, addresses, phone numbers, and other personal information provided by users.

The Name and Content of Hazardous Substances

Part Name	Hazardous Substances					
	Pb	Hg	Cd	Cr(VI)	PBB	PBDE
Lens Shell	○	○	○	○	○	○
Inner Mechanics	×	○	○	○	○	○
Optics	○	○	○	○	○	○
Other Parts	○	○	○	○	○	○

This table is formulated in accordance of SJ/T11364.

○: Indicates that the concentration of the hazardous substance in all homogeneous materials in the parts is below the relevant threshold of the GB/T26572 standard.

×: Indicates that the concentration of the hazardous substance of at least one of all homogeneous materials in the parts may be above the relevant threshold of the GB/T26572 standard.

The "×" in the above table indicates that there are one or more exemptions are applied in the parts stated in RoHS (2011/65/EU).

目录

简介	1
安全注意事项	1
镜头部件	2
镜头控制	3
后焦调节	5
1.准备工作	5
2.调节后焦	6
技术规格	7
售后服务	8
产品中有害物质的名称及含量	9

阅读小贴士

点击跳转

用户可以通过目录了解说明书整体结构，点击标题或链接即可跳转到相应页面。

快速搜索关键词

PDF电子文档可以使用查找功能快速搜索关键词。例如在WPS PDF文档中，Windows用户使用快捷键Ctrl+F，Mac用户使用Command+F即可快速搜索关键词。

简介

感谢您购买本系列产品!

观 (Gnosis) 系列是DZOFILM旗下的全画幅高性能微距定焦镜头, 可以让您在视频创作时还原拍摄细节, 色彩通透、过渡均匀自然, 适合在拍摄花卉昆虫等微观场景下使用。它能带来纯净而生动的电影质感, 300°的对焦环行程, 让画面焦点转换控制更自然精准。

镜头114mm的前端口径作为影视工业的标准尺寸, 和拍摄配件如遮光斗等兼容性良好, 使拍摄更轻松自如。

安全注意事项

- 请勿透过镜头或摄影机观看太阳或明亮的光源, 否则会使视力受损;
- 切勿使用涂料稀释剂或苯等有机溶剂清洁镜头;
- 不使用镜头时, 请盖上镜头前后盖;
- 为防止发霉, 请将镜头和滤镜存放在阴凉、干燥的地方, 切不可存放在直射阳光下, 也不要与石脑油或樟脑丸放在一起;
- 请保持镜头干燥, 如受潮或有水滴请擦拭干净后存放;
- 勿将镜头放置在加热器旁或其他极其炎热的地方, 可能导致损坏或变形;
- 请使用吹气球去除镜头或滤镜玻璃表面的灰尘, 若要去除污点和指纹, 可使用一块滴有少许镜头清洁剂的干净软绵布或镜头清洁纸, 以圆周运动方式从里向外进行清洁, 注意不要留下污渍, 也不要用手指触摸玻璃;

镜头部件

- ① 镜头前盖
- ② 镜头标记
- ③ 对焦环
- ④ 支撑底座孔*1 (M3/8-16英制牙, 深9mm)
安装孔*2 (M3, 深3mm)
- ⑤ 光阑环
- ⑥ 卡口后盖
- ⑦ 放大倍数、曝光补偿标识

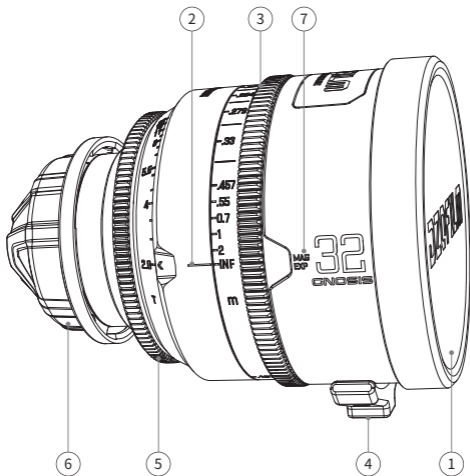

镜头控制

对焦控制

旋转对焦环，可增加或减少对焦距离，从而调整画面中的焦点位置。

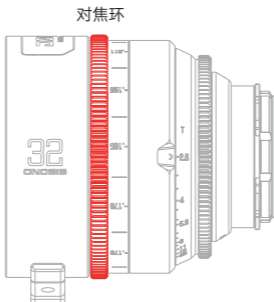

光圈控制

旋转光圈环，可放大或缩小光孔直径，调整画面明暗度以及被摄主体的背景虚化效果。

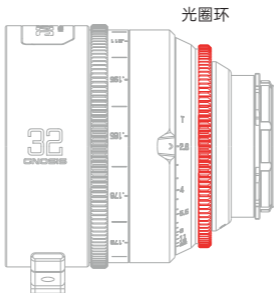

放大倍率、曝光补偿标识

放大倍率：指的是当前对焦距离下的放大倍率

曝光补偿：指的是当前放大倍率下，实际T值跟当前光圈环标的T值差异，如补偿**4.18**，就是该倍率下实际T值=当前光圈环的T值+**4.18**

放大倍率、曝光补偿标识

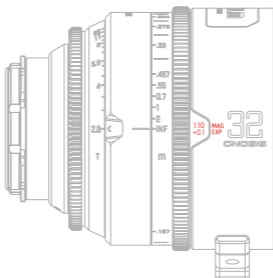

后焦调节

观 (Gnosis) 系列镜头在出厂前会按照标准调整后焦，但不同摄影机的法兰距在出厂时可能会有一点不同，为了方便与不同的摄影机匹配，达到最佳成像效果，需要进行后焦调节操作。

1.准备工作

以下操作以观 (Gnosis) 系列32mm镜头为例

步骤一：准备好拍摄对象和校准工具。可使用“星状测试图”，或使用其它黑白相间的、对比度较高的拍摄对象。在官网下载“定焦镜头后焦校准工具”[\(点击此处跳转\)](#)

提示：可前往“DZOFILM官网-资料下载-后焦调整星图”处下载[\(点击此处跳转\)](#)

步骤二：将镜头安装到相机或摄影机上并调整光圈为T4；

步骤三：将“定焦镜头后焦校准工具”贴在0.33m对焦刻度处（或选择1'1的对焦刻度线），刻度指针与“定焦镜头后焦校准工具”中间横线平齐；

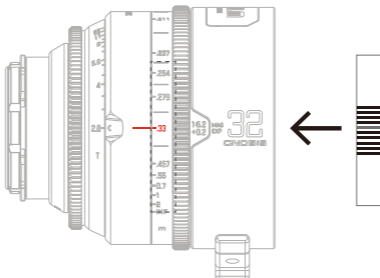

步骤四：将拍摄对象放置在距离相机成像面约0.33m处，并调整其位置在画面中心。

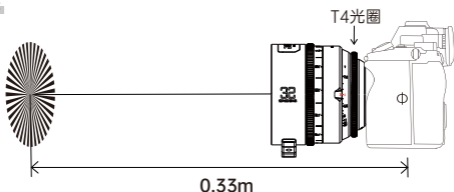

将拍摄对象在距离相机成像画面“Φ”标记处约0.33m放置，
将拍摄对象位于画面中心。

2. 调节后焦

调节过程，请执行以下步骤。

步骤一： 旋转对焦环直至画面达到清晰状态，以“定焦镜头后焦校准工具”中间的横线为基准，观察此刻刻度指针的位置，并观察刻度指针偏移的横线条数；

注 意： 若偏向无穷远方向，则代表刻度偏移值为正数；
若偏向最近对焦距离方向，则代表刻度偏移值为负数；
若超过三格横线，则用对应数值加减即可。

举 例： 若刻度指针指向的刻度线朝最近对焦距离方向偏移3格，则刻度偏移值为-3；
若刻度指针指向的刻度线朝无限远距离方向偏移4格，则刻度偏移值为+4，此时需把“+3”的垫片值加上“+1”的垫片值即可。

步骤二： 根据刻度偏移值，参考下表调整相应的垫片，即可完成调后焦调整。

观 (GNOSIS) 系列后焦调整表									
偏移方向			最近对焦距离方向偏移				无限远方向偏移		
焦距	刻度基准值	刻度偏移值	-3	-2	-1	0	+1	+2	+3
32mm	0.33m/1'1"	后焦垫片调整 参考值(mm)	-0.68	-0.52	-0.25	0	+0.22	+0.41	+0.65
65mm	0.32m/12.6"		-1.7	-1.16	-0.55	0	+0.56	+1.1	+1.7
90mm	0.291m/1'		-2.14	-1.4	-0.88	0	+0.72	+1.48	+2.32

提 示： 后焦垫片调整值，“+”代表要增加垫片厚度，“-”代表减少垫片厚度。

技术规格

技术规格			
名称	Gnosis (观)		
颜色	黑色		
焦距	32mm	65mm	90mm
卡口	LPL/PL/EF		
光圈	T2.8-T22		
最大像面	φ 46.5mm(VV/FF)		
镜片组	11片9组	11片8组	11片9组
法兰距	44mm(LPL)/52mm(PL)/44mm(EF)		
最近对焦距离 (米制/英制)	0.167m/6.6in	0.237m/9.36in	0.258m/10.2in
最大放大倍率	1.0X	1.33X	1.5X
光圈控制	手动 (光圈环旋转最多55°)	手动 (光圈环旋转最多67°)	手动 (光圈环旋转最多68°)
对焦控制	手动(对焦环旋转最多300°)		
前端直径 (米制/英制)	φ 114mm		
长度 (米制/英制)	112mm		
叶片数量	16		
滤镜尺寸	M105		
齿轮齿距	0.8M		
材质	铝合金		
重量	1460g	1447.5g	1280.5g

售后服务

如何获得售后服务：在保修期间，若产品不能实现所保证的功能，请联系DZOFILM以获取相应的售后服务。保修以外的服务可能会收取费用。售后服务政策的内容可能因地而异，如欲了解本地信息，请联系DZOFILM。

保修服务：凡是从我们授权的代理处购买的产品，自产品购买之日起，我们提供一年的保修服务。若产品是在按照用户手册正常使用期间发生故障，您可在保修期内将其送回至销售点进行保修，除运费、保险费等（运）杂费用外，保修服务免费提供。保修期根据出售国或销售地的不同而异；由于在保修期内进行保修时将需要使用收据或购买凭证，请将注明日期的收据或其他购买凭证存放在稳妥的地方。保修中所更换下来的配件归DZOFILM所有。

保修期外的服务：本产品的配件可在停产后大约持有5年，用户一般可在此期间请求维修、更换服务，具体费用标准以本地信息为准。在配件不可用的情况下，可能为用户提供同等产品，此时与原产品耗材和配件的兼容性不予保证。为杜绝浪费，DZOFILM可能会收集返修部件或产品。

售后服务周期：我们收到产品后，一般情况下会在两周内完成售后服务，这不包括来回运输的时间。如有特殊情况，我们会提前通知您。

非售后政策保障范围：本政策不涵盖以下情况，但可实行收费维修：

- × 无使用收据或购买凭证；
- × 发生非官方说明书指导的私自改装、拆解，以及自行维修等行为而造成的损坏；
- × 未按说明书指导的不正确安装和操作所造成的损坏；
- × 未按说明书指导的存放环境导致的产品损坏；
- × 在恶劣的环境下使用导致的损坏，如雨天、沙尘、潮湿环境等；
- × 与非DZOFILM认证的第三方部件同时使用时发生可靠性及兼容性问题导致的损坏；
- × 任何第三方产品所导致的故障或损坏；
- × 因不可抗力发生的损坏；
- × 随本产品之附件消耗品及选购件等。

个人联系信息的使用：DZOFILM遵循所有关于处理用户所提供的姓名、地址、电话号码以及其他个人信息的现行法律和法规。

产品中有害物质的名称及含量

部件名称	有害物质					
	铅 (Pb)	汞 (Hg)	镉 (Cd)	六价铬 (Cr(VI))	多溴联苯 (PBB)	多溴二苯醚 (PBDE)
镜头外壳部件	○	○	○	○	○	○
机械部件	×	○	○	○	○	○
光学部件	○	○	○	○	○	○
其它部件	○	○	○	○	○	○

本表格依据SJ/T11364的规定编制。

○:表示该有害物质在该部件所有均质材料中的含量均在GB/T26572规定的限量要求以下。

×:表示该有害物质至少在该部件的某一均质材料中的含量超出GB/T26572规定的限量要求。

对于表示"×"的情况,属于欧盟RoHS指令(2011/65/EU)的豁免项目。

Shenzhen Dongzheng Optical Technology Co., Ltd.

Floor 6, Building One, Xinwuxia Industrial Area, No.32, Cuibao Rd.,
Baolong St., Longgang Dist., Shenzhen 518000, China

 www.dzofilm.com

深圳市东正光学技术股份有限公司

广东深圳市龙岗区宝龙街道翠宝路32号
新屋吓工业园1栋6楼整层

 www.dzofilm.com



 www.dzofilm.com



 WECHAT: DZOFILM