

**DZOFILM**  
MAKE YOUR MOVIE

# PAVO ANAMORPHIC PRIME LENS USER'S MANUAL

翎系列变形宽银幕定焦镜头使用说明书

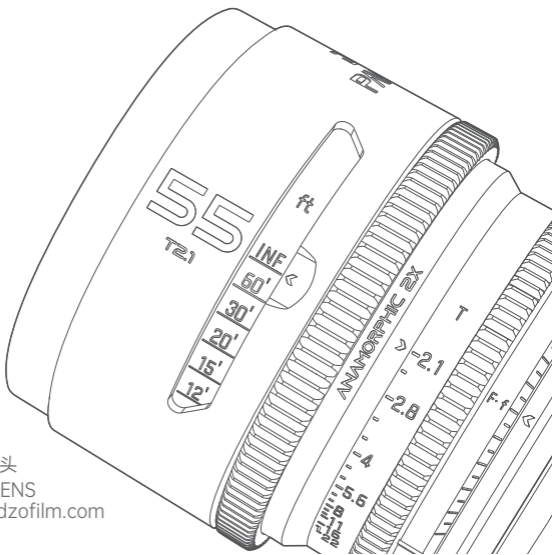

电影镜头  
CINE LENS  
[www.dzofilm.com](http://www.dzofilm.com)

# Contents

---

Introduction .....	1
Safety Notes.....	1
Lens Parts .....	2
Lens Control.....	3
Flange Back Adjustment.....	5
1. Preparation.....	5
2. Flange Back Adjustment .....	5
PL Mount Assembly Instruction.....	6
EF Mount Assembly Instruction.....	7
Specification.....	8
After-sales Service .....	9
The Name and Content of Hazardous Substances.....	11

## Note

### Click to go

Users can read the table of content(TOC) to have an overview of the Pavo Product Manual. Please click on the title or link to jump to the TOC.

### Search keyword

The Search-keyword Function is available in PDF Document. For example, In WPS Office, Windows users can search keywords with the keyboard shortcut <Ctrl+F> and Mac users can execute the same function with shortcut <Command+F>.

## **Introduction**

---

Thank you for purchasing this product !

Pavo series is a set of high-performance S35 anamorphic prime lenses produced by DZOFILM. Bring a wider view to your video creation. They are suitable for different kinds of projects, documentaries, commercials, feature films etc. Unique streak, waterfall out-of-focus effects and soft bokeh add a sense of cinematic artistry to your creations.

## **Safety Notes**

---

- Please do not watch the sun or bright light source through the lens or camera, otherwise it will cause visually disabled;
- Never use organic solvents such as paint thinner or benzene to clean the lens;
- Attach the front and rear caps when the lens is not in use;
- Store the lens and filter in cool, dry locations to prevent mold and rust. Do not store in direct sunlight or with naphtha or camphor moth balls;
- Please keep the lens dry and wipe the water droplets off if there are water droplets on the glass surface;
- Leaving the lens near heater or in other extremely hot locations could cause damage or warping;
- Use a blower to remove dust and lint from the glass surfaces of the lens or filter. To remove smudges and fingerprints, apply a small amount of lens cleaner to a soft, clean cotton cloth or lens-cleaning tissue and clean from the center outwards using a circular motion. Do not leave smears or touch the glass with your finger.

## Lens Parts

- ① Front Cap
- ② Lens Mark
- ③ Focusing Ring
- ④ Aperture Ring
- ⑤ Flange Back Adjustment Locking /Unlocking Screw
- ⑥ Flange Back Adjustment Ring
- ⑦ Rear Cap
- ⑧ Holes for Supporting Base\*1 (M3/8-16 thread, 9mm deep)  
Mounting holes \*2 (M3,3mm deep)

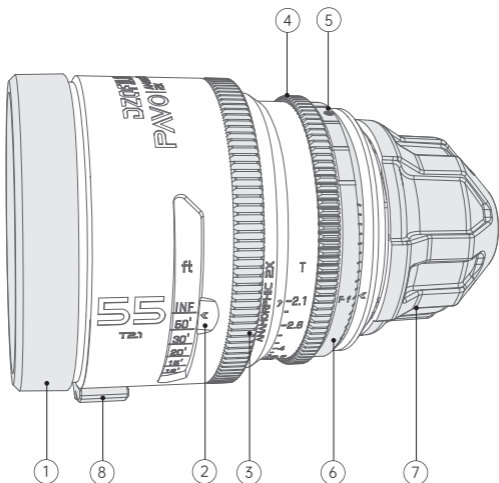

# Lens Control

---

## Focus Control

Rotate the focus ring to increase or decrease the focus distance, changing the focus point.

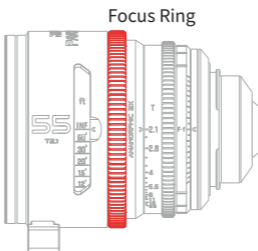

## Aperture Control

Rotate the aperture ring to enlarge or reduce the diameter of the aperture, adjusting the brightness of the image and the bokeh effect of the subject's background.

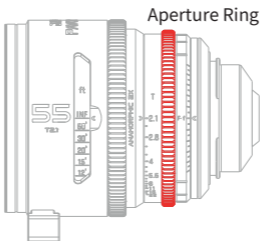

## Flange Back Adjustment

Rotate the flange back adjustment ring to adjust the flange back distance to keep the focusing marks accurate.

**Note:** Adjustable flange back range  $\pm 0.2\text{mm}$ .

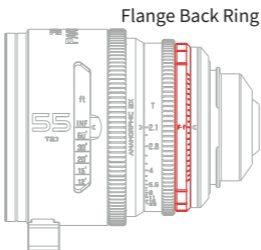

# Flange Back Adjustment

---

Every Pavo lens will process flange back adjustment on standard. But to the tolerance of different cameras, to achieve the best performance of this product and to match the cameras, please adjust flange back of the product.

## 1. Preparation

**Step One:** Ready your subject. You can use a "Star Chart", or other high-resolution black-and-white objects.

**Note:** You can download and print the chart on "DZOFILM website -Support-Download Center-Tool-Star Chart For Adjusting Back Flange"  
[\(Click to jump to the website\)](#)

**Step Two:** Attach the lens to the camera and adjust the aperture to **T4**.

## 2. Flange Back Adjustment

**Step One:** Turn the lens facing to any open direction and rotate the focus ring to its infinity-direction scale. When using a "Star Chart", keep a distance of ten meters or more from it.

**Step Two:** Use the **Torx T6 screwdriver** to loosen the countersunk torx screw in the flange-back-adjustment ring **counterclockwise**. Rotate the flange-back-adjustment ring until the focusing object in the infinity direction becomes the sharpest.

**Step Three:** Tighten the countersunk torx screw **clockwise** to finish the adjustment.

**Note:** The above adjustment is applicable when the flange-back-adjustment range is  $\pm 0.2\text{mm}$ . If it exceeds  $\pm 0.2\text{mm}$ , please contact DZOFILM dealers or the official After-service.

## PL Mount Assembly Instruction

Align the slot on PL mount to the pin on the rear of lens. Then lay the PL mount flat on the lens rear and slightly rotate the mount. If the mount cannot move, that means the mount sits in right place. Tighten the 8pcs of M2\*5 screws symmetrically on by one to keep the balance of lens mount.

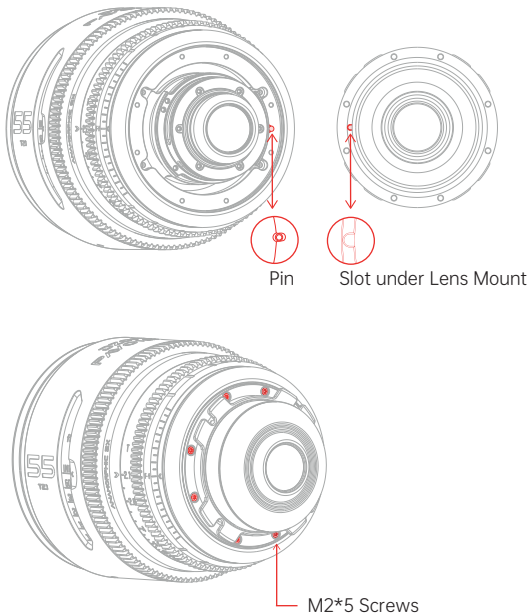



## EF Mount Assembly Instruction

Align the slot on EF mount to the pin on the rear of lens. Then lay the PL mount flat on the lens rear and slightly rotate the mount. If the mount cannot move, that means the mount sits in right place. Tighten the 7pcs of M2\*18 screws symmetrically on by one to keep the balance of lens mount.

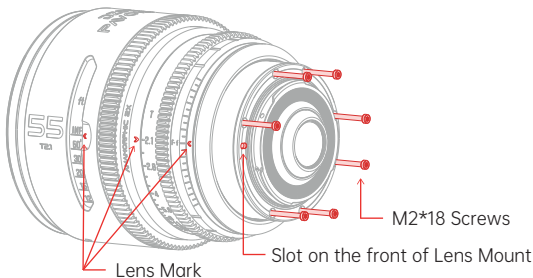
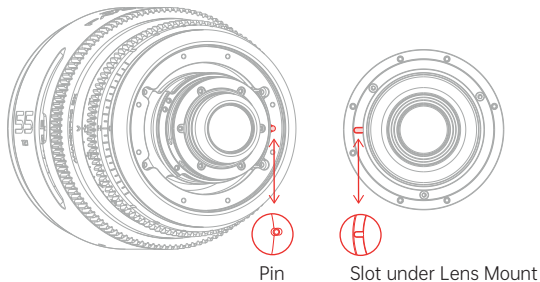

**Note :** No shim adjustment after changing lens mount.  
Do not lay the lens-mount end down to avoid lens damage.

## Specification

Name	PAVO								
Colour	Space Grey								
Focal Length	28mm	32mm	40mm	55mm	Macro 65mm	75mm	100mm	135mm	180mm
Mount	PL/EF								
Aperture	T2.1-22				T2.8-22	T2.1-22	T2.4-22	T2.5-22	T2.8-22
Image Circle	φ 31.5mm (S35)								
Construction of Optics	15 Elements in 13 Groups		15 Elements in 14 Groups	14 Elements in 13 Groups	17 Elements in 12 Groups	15 Elements in 14 Groups	14 Elements in 13 Groups	16 Elements in 11 Groups	
Flange Distance	52mm (PL) /44mm (EF)								
Angle of view H/V (Super 35)	103°/36°	88°/32°	72°/26°	53°/19°	44°/17°	40°/15°	29°/11°	21°/8°	12°/5°
Close Focus (from sensor plane)	0.4m/1ft4in		0.45m/1ft6in	0.6m/2ft	0.366m/1ft2.4in	0.84m/2ft9in	0.95m/3ft1in	0.99m/3ft3in	1.04m/3ft5in
Max.Mag.Ratio	/				0.5X	/			
Squeeze Factor	2X								
Iris Control	Manual (79°)	Manual (59°)	Manual (58°)	Manual (63°)	Manual (73°)	Manual (67°)	Manual (69°)	Manual (79°)	
Focus Control	Manual (270°)				Manual (300°)	Manual (270°)			
Front Dia.	φ 95mm/3.74"								
Length (from lens front to flange plane)	106.3mm/ 4.19"	105.7mm/ 4.16"	107.6mm/ 4.24"	108.4mm/ 4.26"	160mm/ 6.3"	126.9mm/ 4.99"	143.1mm/ 5.63"	160mm/ 6.3"	
Iris Blade	14				16				
Filter Size	M86								
Gear Pitch	0.8 Mod								
Material	Aluminium alloy								
Weight(Product)	1203.1g	1278.4g	1300g	1262g	约1963.6g	1466.3g	1654.6g	约1994.3g	约1950.8g

# After-sales Service

---

## How to Obtain After-Sales Service

If a product does not function as warranted during the warranty period, you may obtain after-sales service by contacting DZOFILM support team or DZOFILM's authorized dealers. Charges may apply for services not covered by this After-Sales Policy. The After-Sales Policy varies with the country or region of purchase. Please contact DZOFILM for information specific to your location.

## Warranty Service

DZOFILM grants a minimum warranty period of one year from the date of purchase for lenses purchased through DZOFILM's official dealers. DZOFILM warrants that each DZOFILM product that you purchase will be free from material and workmanship defects under normal use in accordance with DZOFILM's user manual and accompanying documentation during the warranty period. You may claim warranty service by returning it to the point of purchase. The owner is responsible for all shipping costs. The warranty period varies with the country or region of purchase. Stored proof of purchase in a safe place, as you will need to provide a valid proof-of-purchase for the warranty service. Parts replaced during the warranty service become DZOFILM's property.

## Service Outside the Warranty Period

Request for after-sales service will normally be accepted within a period of roughly 5 years following the end of production, during which time spares will be kept on hand, although owners may be offered an equivalent product during this period in the event that spares are not available. The specific cost standard is subject to DZOFILM's quotation. Compatibility with consumables and accessories for the original product is not guaranteed. To prevent waste, DZOFILM may collect returned parts or products.

## Service Turn Around Time

After we receive the product, the after-sales service will generally be completed within two weeks. This turn around time does not include the time of return shipping. If there are special circumstances, we will notify you in advance.

### **What This After-Sales Policy Does NOT Cover**

This after-sales policy does not cover the following and charges may apply:

- × No valid proof-of-purchase of the product;
- × Damage caused by unauthorized modification, disassembly, or repair not in accordance with official instructions or manuals;
- × Damage caused by improper installation and operation not in accordance with official instructions or manuals;
- × Damage caused by the storage environment not in accordance with official instructions or manuals;
- × Damage caused by operation in bad weather or environment (i.e. rain, sand/dust storms, humid environment, etc.);
- × Damage caused by, any third party products, including those that DZOFILM may provide or integrate into the DZOFILM product at your request;
- × Damage caused by any third-party product;
- × Damage caused by force majeure;
- × Consumable accessories and optional parts that come with this product.

### **Privacy**

DZOFILM obeys all applicable laws and regulations concerning the handling of names, addresses, phone numbers, and other personal information provided by users.

## The Name and Content of Hazardous Substances

---

Part Name	Hazardous Substances					
	Pb	Hg	Cd	Cr(VI)	PBB	PBDE
Lens Shell	○	○	○	○	○	○
Inner Mechanics	×	○	○	○	○	○
Optics	○	○	○	○	○	○
Other Parts	○	○	○	○	○	○

This table is formulated in accordance of SJ/T11364.

○: Indicates that the concentration of the hazardous substance in all homogeneous materials in the parts is below the relevant threshold of the GB/T26572 standard.

×: Indicates that the concentration of the hazardous substance of at least one of all homogeneous materials in the parts may be above the relevant threshold of the GB/T26572 standard.

The "×" in the above table indicates that there are one or more exemptions are applied in the parts stated in RoHS (2011/65/EU).

# 目录

简介 .....	1
安全注意事项 .....	1
镜头部件 .....	2
镜头控制 .....	3
后焦调节 .....	5
1. 准备工作 .....	5
2. 调节后焦 .....	5
PL卡口安装说明 .....	6
EF卡口安装说明 .....	7
技术规格 .....	8
售后服务 .....	9
产品中有害物质的名称及含量 .....	10

## 阅读小贴士

### 点击跳转

用户可以通过目录了解说明书整体结构，点击标题或链接即可跳转到相应页面。

### 快速搜索关键词

PDF电子文档可以使用查找功能快速搜索关键词。例如在WPS PDF文档中，Windows用户使用快捷键Ctrl+F，Mac用户使用Command+F即可快速搜索关键词。

## 简介

---

感谢您购买本系列产品！

翎（PAVO）系列是DZOFILM旗下的S35高性能变形宽银幕定焦镜头，为您的视频创作带来更宽广的视野。适合在纪录片、广告、电影等场景使用。独特的拉丝、瀑布焦外效果和柔美的椭圆光斑，增添创作的电影艺术感。

## 安全注意事项

---

- 请勿透过镜头或摄影机观看太阳或明亮的光源，否则会使视力受损；
- 切勿使用涂料稀释剂或苯等有机溶剂清洁镜头；
- 不使用镜头时，请盖上镜头前后盖；
- 为防止发霉，请将镜头和滤镜存放在阴凉、干燥的地方，切不可存放在直射阳光下，也不要与石脑油或樟脑丸放在一起；
- 请保持镜头干燥，如受潮或有水滴请擦拭干净后存放；
- 勿将镜头放置在加热器旁或其他极其炎热的地方，可能导致损坏或变形；
- 请使用吹气球去除镜头或滤镜玻璃表面的灰尘，若要去除污点和指纹，可使用一块滴有少许镜头清洁剂的干净软绵布或镜头清洁纸，以圆周运动方式从里向外进行清洁，注意不要留下污渍，也不要用手指触摸玻璃。

## 镜头部件

- ① 镜头前盖
- ② 镜头标记
- ③ 对焦环
- ④ 光阑环
- ⑤ 后焦调节锁定/解锁螺丝
- ⑥ 后焦调节环
- ⑦ 卡口后盖
- ⑧ 支撑底座孔\*1  
(M3/8-16英制牙, 深9mm)  
安装孔\*2  
(M3, 深3mm)

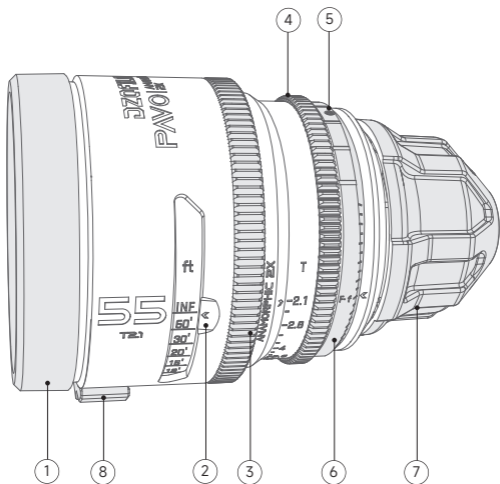



## 镜头控制

### 对焦控制

旋转对焦环，可增加或减少对焦距离，从而调整画面中的焦点位置。

对焦环

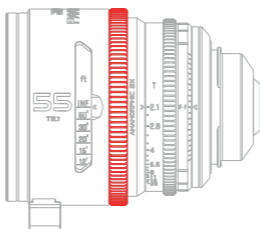

### 光圈控制

旋转光圈环，可放大或缩小光孔直径，调整画面明暗度以及被摄主体的背景虚化效果。

光圈环

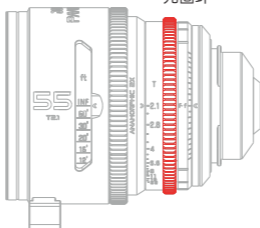

## 后焦调节

旋转后焦调节环，可增加或减少后焦距离，从而调整恢复对焦刻度的准确性。

注：可调节的后焦范围为 $\pm 0.2\text{mm}$

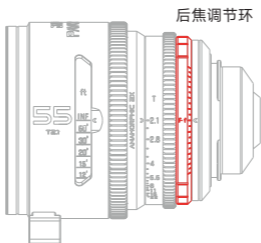

## 后焦调节

翎(PAVO)系列镜头在出厂前会按照标准调整后焦，但不同摄影机的法兰距在出厂时可能会有一点不同，为了方便与不同的相机匹配，达到最佳成像效果，需要进行后焦调节操作。

### 1. 准备工作

**步骤一：**准备好拍摄对象，可使用“星状测试图”，或使用其他黑白相间的、对比度较高的拍摄对象。

**提示：**可前往“DZOFILM 官网-服务与支持-下载中心-工具-后焦调整镜头-后焦调整星图”处下载 [\(点击此处跳转\)](#)

**步骤二：**镜头安装到相机或摄影机上并调整光圈为**T4**。

### 2. 调节后焦

**步骤一：**将镜头对准无穷远处的被摄物，并将对焦环旋转至无穷远刻度。使用“星状测试图”时，与星图保持十米或以上的距离。

**步骤二：**使用**梅花T6螺丝刀**，将后焦调节环上的无头螺丝**逆时针**拧松。旋转后焦调节环，直至画面中的无穷远处的被摄物处于最清晰状态。

**步骤三：**此时**顺时针**拧紧后焦调节环上的无头螺丝，完成后焦调节。

**注：**该方法可调节的后焦范围为**±0.2mm**。若超出该范围，请联系经销商或官方返厂处理。

## PL卡口安装说明

先根据镜头将PL卡口底部的销钉槽，对准镜头后端的销钉，平放在镜头后端，左右轻轻扭动卡口，有感受到停顿感，说明卡口已安装平稳到位。然后依次对称锁入8颗M2\*5螺丝。

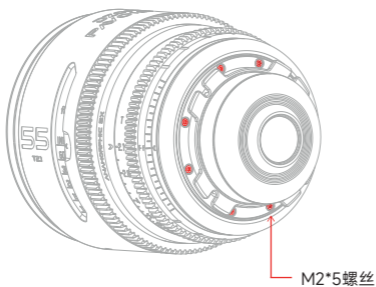
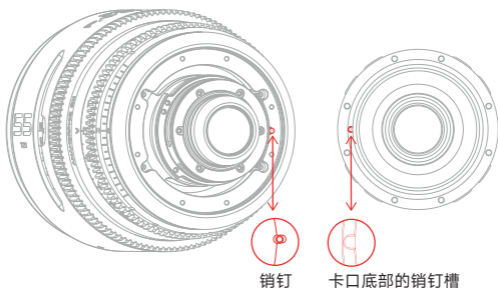

## EF卡口安装说明

将EF卡口底部的销钉槽，对准镜头后端的销钉，平放在镜头后端，左右轻轻扭动卡口，有感受到停顿感，说明卡口已安装平稳到位。然后依次对称锁入7颗M2\*18螺丝。

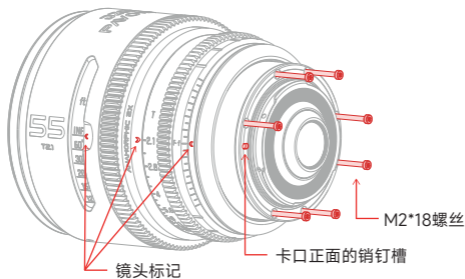
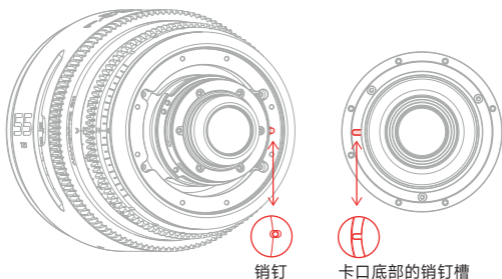

**提示：**更换卡口后无需调整垫片；  
请勿将镜头卡口端朝下放置，以免损伤镜头。

## 技术规格

名称	PAVO(翎)								
颜色	太空灰								
焦距	28mm	32mm	40mm	55mm	微距 65mm	75mm	100mm	135mm	180mm
卡口	PL/EF								
光圈	T2.1-22			T2.8-22	T2.1-22	T2.4-22	T2.5-22	T2.8-22	
最大像面	φ 31.5mm (S35)								
镜片组	15片13组		15片14组	14片13组	17片12组	15片14组	14片13组	16片11组	
法兰距	52mm (PL) / 44mm (EF)								
视场角(水平/垂直) <small>(按S35画幅测算)</small>	103°/36°	88°/32°	72°/26°	53°/19°	44°/17°	40°/15°	29°/11°	21°/8°	12°/5°
最近对焦距离 <small>(从传感器平面)</small>	0.4m/1ft4in		0.45m/1ft6in	0.6m/2ft	0.366m/ 1ft2.4in	0.84m/2ft9in	0.95m/3ft1in	0.99m/3ft3in	1.04m/3ft5in
最大放大倍率	/				0.5X	/			
变形倍率	2X								
光圈控制	手动(79°)	手动(59°)	手动(58°)	手动(63°)	手动(73°)	手动(67°)	手动(69°)	手动(79°)	
对焦控制	手动(270°)				手动(300°)	手动(270°)			
前端直径	φ 95mm/3.74"								
长度 <small>(从镜头前端面至法兰面)</small>	106.3mm/ 4.19"	105.7mm/ 4.16"	107.6mm/ 4.24"	108.4mm/ 4.26"	160mm/ 6.3"	126.9mm/ 4.99"	143.1mm/ 5.63"	160mm/ 6.3"	
叶片数量	14		16						
滤镜尺寸	M86								
齿轮齿距	模数 0.8								
材质	铝合金(外观件)								
重量	约1203.1g	约1278.4g	约1300g	约1262g	约1963.6g	约1466.3g	约1654.6g	约1994.3g	约1950.8g

## 售后服务

**如何获得售后服务：**在保修期间，若产品不能实现所保证的功能，请联系DZOFILM以获取相应的售后服务。保修以外的服务可能会收取费用。售后服务政策的内容可能因地而异，如欲了解本地信息，请联系DZOFILM。

**保修服务：**凡是从我们授权的代理处购买的产品，自产品购买之日起，我们提供一年的保修服务。若产品是在按照用户手册正常使用期间发生故障，您可在保修期内将其送回至销售点进行保修，除运费、保险费等（运）杂费用外，保修服务免费提供。保修期根据出售国或销售地的不同而异；由于在保修期内进行保修时将需要使用购买凭证，请将注明日期的购买凭证存放在稳妥的地方。保修中所更换下来的配件归DZOFILM所有。

**保修期外的服务：**本产品的配件可在停产后大约持有5年，用户一般可在此期间请求维修、更换服务，具体费用标准以本地信息为准。在配件不可用的情况下，可能为用户提供同等产品，此时与原产品耗材和配件的兼容性不予保证。为杜绝浪费，DZOFILM可能会收集返修部件或产品。

**售后服务周期：**我们收到产品后，一般情况下会在两周内完成售后服务，这不包括来回运输的时间。如有特殊情况，我们会提前通知您。

**非售后政策保障范围：**本政策不涵盖以下情况，但可实行收费维修：

- × 无购买凭证；
- × 发生非官方说明书指导的私自改装、拆解，以及自行维修等行为而造成的损坏；
- × 未按说明书指导的不正确安装和操作所造成的损坏；
- × 未按说明书指导的存放环境导致的产品损坏；
- × 在恶劣的环境下使用导致的损坏，如雨天、沙尘、潮湿环境等；
- × 与非DZOFILM认证的第三方部件同时使用时发生可靠性及兼容性问题导致的损坏；
- × 任何第三方产品所导致的故障或损坏；
- × 因不可抗力发生的损坏；
- × 随本产品之附件消耗品及选购件等。

**个人联系信息的使用：**DZOFILM遵循所有关于处理用户所提供的姓名、地址、电话号码以及其他个人信息的现行法律和法规。

## 产品中有害物质的名称及含量

部件名称	有害物质					
	铅 (Pb)	汞 (Hg)	镉 (Cd)	六价铬 (Cr(VI))	多溴联苯 (PBB)	多溴二苯醚 (PBDE)
镜头外壳部件	○	○	○	○	○	○
机械部件	×	○	○	○	○	○
光学部件	○	○	○	○	○	○
其它部件	○	○	○	○	○	○

本表格依据SJ/T11364的规定编制。

○:表示该有害物质在该部件所有均质材料中的含量均在GB/T26572规定的限量要求以下。

×:表示该有害物质至少在该部件的某一均质材料中的含量超出GB/T26572规定的限量要求。

对于表示"×"的情况,属于欧盟RoHS指令(2011/65/EU)的豁免项目。



## Shenzhen Dongzheng Optical Technology Co., Ltd.

Floor 6, Building One, Xinwuxia Industrial Area, No.32, Cuibao Rd.,  
Baolong St., Longgang Dist., Shenzhen 518000, China

 [www.dzofilm.com](http://www.dzofilm.com)

## 深圳市东正光学技术股份有限公司

广东深圳市龙岗区宝龙街道翠宝路32号  
新屋吓工业园1栋6楼整层

 [www.dzofilm.com](http://www.dzofilm.com)



 [www.dzofilm.com](http://www.dzofilm.com)



 WECHAT: DZOFILM